

GURLEY SERIES Vx20 VIRTUAL ABSOLUTE ENCODER

MOTION TYPE:

ROTARY

USAGE GRADE:

INDUSTRIAL

OUTPUT:

VIRTUAL ABSOLUTE

MAX RESOLUTION:

2^{19} (524,288) STEPS/REV
(WITH SEPARATE ELECTRONICS)



BUILT IN TESTING - ABSOLUTE OUTPUT

The **Series Vx20** combines the opto-mechanical simplicity and ruggedness of an incremental encoder with the system reliability and interfacing ease of an absolute encoder. Utilizing Gurley's unique **Virtual Absolute** technology, the **Vx20** is less expensive and more reliable than any conventional absolute encoder of comparable resolution and accuracy. The **Vx20** is available in two accuracy grades and a variety of mechanical configurations. All **Vx20s** share these features:

- LED illumination for long life 100,000 hours
- Differential photodetectors for stable signals
- Small number of wires from the encoder
- Availability of non-binary resolutions
- Differential output for noise immunity
- IP64 sealing for harsh environments

ingenuity[®]@work

ISO
9001
CERTIFIED

Gurley Precision Instruments
514 Fulton Street
Troy, NY 12180 U.S.A.
(800) 759-1844, (518) 272-6300, fax (518) 274-0336,
Online at www.gurley.com, e-mail: info@gurley.com



SPECIFICATIONS

INPUT POWER

+5VDC \pm 0.25V @ 75 mA max.

OUTPUT SIGNALS

Complemented buffered sinusoids.

Sin and Cos: 1 Vpp typical. Pseudorandom index track: 0.25Vpp typical.

	See Note	Model V120	Model V220
Line count on disc	1	2048 (2^{11})	
Initialization angle		1.93°	
Accuracy, \pm arcsec (at 20°C)	2	80	40
Maximum output frequency	3	50 kHz = 1,465 RPM (Max. speed may be limited by subsequent electronics; see data sheet for Model VB or VF interpolating decoder.)	
Maximum weight, oz (g)		6 (170)	
Starting torque, in-oz (N-m) @20°C	4	S: 1.0 (7×10^{-3})	B: 2.0 (14×10^{-3})
Running torque, in-oz (N-m) @20°C	4	S: 0.5 (3.5×10^{-3})	B: 1.0 (7.0×10^{-3})
Moment of inertia, in-oz-s ² (g-cm ²)	4	S: 1.3×10^{-4} (9.0)	B: 2.9×10^{-4} (21.0)
Maximum acceleration, rad/s ²		2.8×10^6	
Operating temperature, °F (°C)		32 to 158 (0 to 70)	32 to 122 (0 to 50)
Storage temperature, °F (°C)		0 to 160 (-18 to 71)	
Humidity, % rh, non-condensing		98	
Shock		50 g, 11 ms	
Vibration		15 g, 0-2000 Hz	
Sealing		IP66 body & cable exit, IP64 at shaft exit	
Bearings	4	S: ABEC 7 B: ABEC 5 grease-lubricated and sealed	
Maximum radial shaft load, lb (N)	5	25 (111)	
Bearing life (with 10-lb radial load)		1×10^9 revolutions	

NOTES:

1. If necessary, the system can provide non-binary resolutions such as 0.005° or 0.1 mrad. Consult factory for details.
2. This is the total encoder error from all sources. Error is defined at the signal transitions and therefore does not include quantization error, which is $\pm 1/2$ quantum. ("Quantum" is the final resolution of the encoder; e.g., for a 16-bit encoder, 1 quantum 20 s.) Accuracy is guaranteed at 20°C.
3. Higher shaft speeds available; contact factory.
4. **S** = solid shaft version; **B** = blind hollow shaft version
5. The maximum recommended shaft load is based on bearing life considerations. If accuracy is critical, axial and especially radial shaft loads should be kept as low as possible.

As part of our continuing product improvement program, all specifications are subject to change without notice.



SPECIFICATIONS

THEORY OF OPERATION- SHORT VERSION

Virtual Absolute (VA) discs and scales are similar to incremental discs and scales in that they contain a cyclic track and an index track. In an incremental encoder, the index occurs at one place in the full travel, but in a VA encoder, the index track is a continuous serial code (similar in appearance to a bar code). You don't know position immediately upon start-up, as you do in a conventional absolute, but after a very short travel, *in either direction and starting from anywhere*, you know exactly where you are. In the **Vx20**, this initialization angle is 1.93°. From then on, the encoder is truly absolute. (There are ways to build a pseudorandom encoder so that absolute information is available on power-up without initializing, but these techniques require far more complex sensing hardware; they often impose slower operation as well. And none of them offers the sophisticated built-in testing of GPI's *Virtual Absolute* technology.)

To complete the system, the **Vx20** is used with one of Gurley's **Interpolating Decoders**. The size of a credit card, it contains patented high-speed circuitry to decode the special serial index track and interpolation to increase the final resolution. In addition to the natural binary position output, a *Status* bit is provided to tell you when the encoder is initialized. This bit is at a logic high whenever the initializing motion is not yet complete, or when some other problem such as supply voltage interruption, electrical noise, damage, or fouling of the disc interferes with the proper code sequence from the index track. When these self-tests are all satisfied, the status bit is low, indicating the position data output is valid.

Final resolution depends on which version of interpolating decoder is used. With the Model **VB**, final resolution is 16 bits (65,536) measuring steps/rev. With the Model **VF**, final resolution is 19 bits (524,288) measuring steps/rev, but the max speed is lower. Please refer to the **Model VB** or **VF** data sheet for complete details.

FLEXIBLE COUPLINGS

	Tether Mount (for B version)	SCA04Exxx Shaft Coupling (for S version)
Wind-Up, arcs/in-oz (arcs/Nm)	negligible	9.7 (1375)
Max. parallel offset, in (mm)	0.005 (0.13)	0.008 (0.2)
Max. axial extension or compression, in (mm)	0.010 (0.25)	0.008 (0.2)
Max. angular misalignment, degrees	2	1
Moment of inertia, in-oz-s ² (g-cm ²)	n/a	4.3x10 ⁻⁴ (30)
Weight, oz (g)	0.13 (4)	1.0 (30)

NOTE:

Flexible couplings are intended to absorb normal installation misalignments and run-outs in order to prevent undue loading of the encoder bearings. To realize all the accuracy inherent in the encoder, the user should minimize misalignments as much as possible.

The model number for the optional shaft coupling is **SCA04E##E** or **##M**, where **##** is taken from the DIA CODE table in the DIMENSION DRAWINGS section.

ELECTRICAL CONNECTIONS

Output Functions	Wire Colors Conn. Code P	Pin #, DA-15P Conn. Code Q	Pin #, DE-15P Conn. Code R	Pin #, AMP 102387-1 Conn. Code V
SIN	Yellow	8	8	4
/ SIN	Brown	7	7	3
COS	Green	5	5	2
/ COS	Orange	4	4	1
IND	Blue	2	2	5
/ IND	White	1	1	6
+V	Red	10	10	7
COMMON	Black	13	13	8
CASE	Bare (shield) *	9	9	10

* The bare wire (shield) is connected to the encoder case.

- Use connector code **V** if the encoder will be connected to a **VB** or **VF** interpolating decoder.
- Use connector code **R** if there will be a **CAX###** extension cable between the encoder and the **VB** or **VF** interpolating decoder.
- Use connector code **Q** if the encoder will be connected to a Model **DVR** display unit. (The **VB** or **VF** interpolating decoder is inside the DVR.)



OUTLINE DIMENSIONS

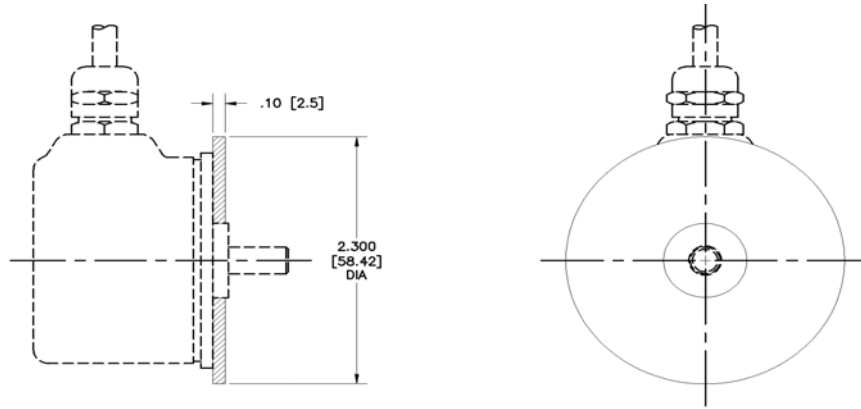

VX20S WITH BASE CODE C

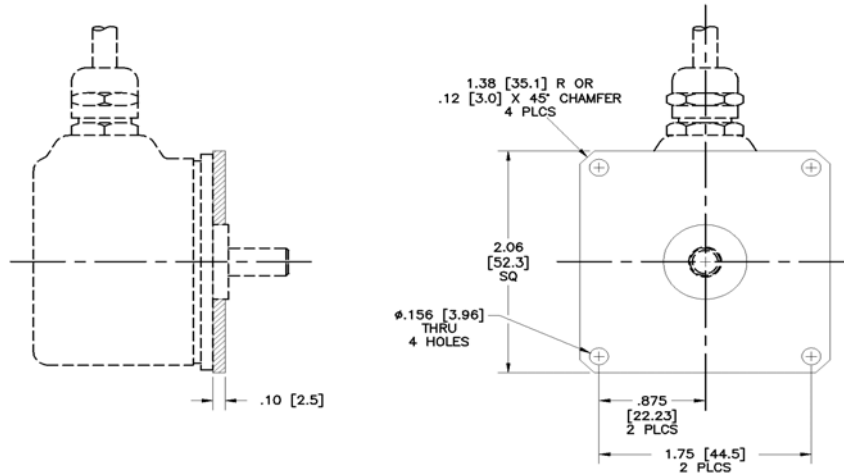

VX20S WITH BASE CODE D

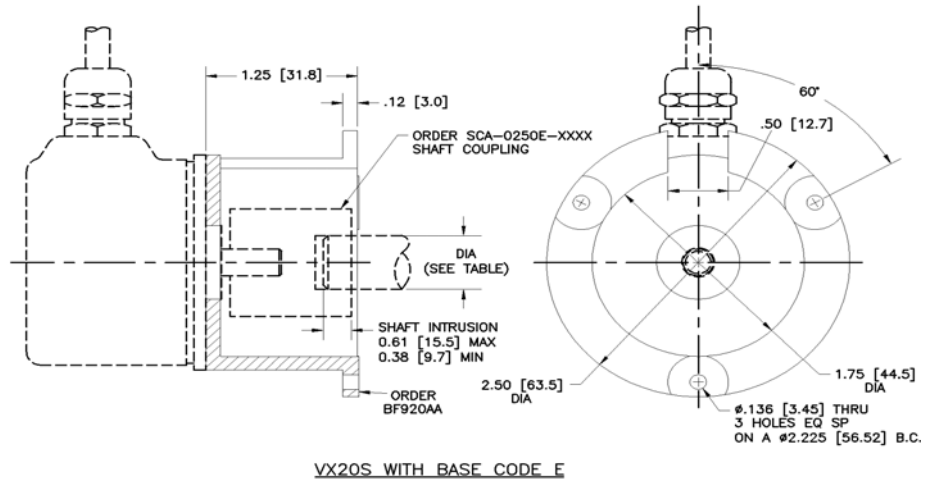

VX20S WITH BASE CODE E

ORDERING INFORMATION

MODEL	SHAFT	RES	OUTPUT	INTERP	BASE	CAB	EXIT	CONN	DIA	TEMP	SPEC
		02048	M	00			S				

MODEL

V120 ±80 s accuracy
V220 ±40 s accuracy

SHAFT

S Solid shaft
B Blind hollow shaft

RES

02048 Disc Resolution, lines.
 (For non-binary resolution, consult factory)

OUTPUT

M Differential buffered sinusoids

INTERP

00 0 bits of internal interpolation

BASE

A Φ 2.0" synchro/face mount
 (**SHAFT = S**)
B Tether mount (**SHAFT = B**)
C Φ 2.3" synchro/face mount
 ((**SHAFT = S**)
D Square-flange mount
 (**SHAFT = S**)
E Bell-flange mount (**SHAFT**

CAB

Cable length, inches (04-99)
18 Standard

EXIT

S Side cable exit

CONN

P Pigtails (no connector)
V Amp 102837-1; use to connect encoder cable to **VB** Interpolating Decoder DE-15P; use if there will be a **CAX###** extension cable between the **Vx35H** and **VB** DA-15P; use with Model **DVR** Display Unit

DIA

See DIAMETER CODE table
E ## = sixteenths of an inch
M ## = millimeters
04E Standard with **SHAFT = S**

TEMP

C 0°C to 70°C operating temperature range

SPEC

Issued at time of order to cover special customer requirements
N No special features

SPECIAL CAPABILITIES

For special situations, we can optimize catalog encoders to provide higher frequency response, greater accuracy, wider temperature range, reduced torque, non-standard line counts, or other modified parameters. In addition, we regularly design and manufacture custom encoders for user-specific requirements. These range from high-volume, low-cost, limited-performance commercial applications to encoders for military, aerospace and similar high-performance, high-reliability conditions. We would welcome the opportunity to help you with your encoder needs.

WARRANTY

Gurley Precision Instruments offers a limited warranty against defects in material and workmanship for a period of one year from the date of shipment.



Gurley Precision Instruments
 514 Fulton Street
 Troy, NY 12180 U.S.A.
 (800) 759-1844, (518) 272-6300, fax (518) 274-0336,
 Online at www.gurley.com, e-mail: info@gurley.com

