

GURLEY SERIES 835S ROTARY INCREMENTAL ENCODERS

MOTION TYPE:

ROTARY

USAGE GRADE:

INDUSTRIAL

OUTPUT:

INCREMENTAL

MAX RESOLUTION:

360,000 COUNTS/REV.*
900,000 COUNTS/REV.**

*INTERNAL ELECTRONICS

**EXTERNAL ELECTRONICS



HIGH PERFORMANCE - INDUSTRIAL ENDURANCE

The **Series 835S** is a family of industrial-grade optical incremental encoders, available in two different models. They have the same mechanical and electrical features, but differ in performance and price.

The following features are common among both models:

- LED illumination for reliability
- Push-pull phototransistors for signal stability
- Optional zero index
- Combination synchro/face mount
- Medium-duty housing, or optional environmentally sealed housing
- Sealed ABEC Class 7 bearings for protection against contaminants
- Precise chrome-on-glass disc

Two Models available:

Model 8135S: Resolution up to 8 times the line count on the disc

Model 8235S: Dual reading heads for improved accuracy. Resolution up to 80 times the line count on the disc.

ingenuity[®]@work

ISO
9001
CERTIFIED

Gurley Precision Instruments
514 Fulton Street
Troy, NY 12180 U.S.A.
(800) 759-1844, (518) 272-6300, fax (518) 274-0336,
Online at www.gurley.com, e-mail: info@gurley.com



SPECIFICATIONS

		SEE NOTE	MODEL 8135S	MODEL 8235S
Maximum line count on disc			11,250	
Max cycles/rev with internal electronics			22,500	90,000
Max counts/rev (after quad edge detection)			90,000	360,000
Max cycles/rev with external electronics		5	N/A	225,000
Max counts/rev with external electronics (after quad edge detection)		5	N/A	900,000
Instrument error, ± arcsec		1,2	30	15
Quadrature error, ± electrical degrees		1,3	30	24
Interpolation error, ± quanta		1,4	0.15	0.10
FREQUENCY RESPONSE kHz	1x square waves		100	
	2x square waves		150	
	5x square waves		N/A	300
	8x square waves		N/A	500
	Up to 20x square waves	5	N/A	1000
Maximum weight, oz (g)			32 (907)	
Starting torque, in-oz (N-m) [at 20°C]			2.0 (14.0 x 10 ⁻³)	
Running torque, in-oz (N-m) [at 20°C]			1.0 (7.0 x 10 ⁻³)	
Moment of inertia, in-oz-s ² (g-cm ²)			2.3 x 10 ⁻³ (164)	
Maximum acceleration, rad/s ²			1 x 10 ⁶	
Operating temperature range, °F (°C)			32 to 158 (0 to 70)	
Storage temperature range, °F (°C)			0 to 160 (-18 to 71)	
Humidity, % RH non-condensing			98	
Shock			50 g, 11 ms	
Vibration			15 g, 0-2000 Hz	

NOTES:

- Total Optical Encoder Error* is the algebraic sum of *Instrument Error* + *Quadrature Error* + *Interpolation Error*. Typically, these error sources sum to a value less than the theoretical maximum. Error is guaranteed at 20°C and is defined at the signal transitions. It does not include quantization error, which is ±1/2 quantum. ("Quantum" is the final resolution of the encoder, after user's 1x, 2x or 4X quadrature decode.)
- Instrument Error* is the sum of disc pattern errors, disc eccentricity, bearing runout and other mechanical imperfections within the encoder. This error tends to vary slowly around a revolution.
- Quadrature Error* is the combined effect of phasing and duty cycle tolerances and other variables in the basic analog signals. This error applies to data taken at all four transitions within a cycle; if data are extracted from 1X square waves on a 1X basis (i.e., at only one transition per cycle), this error can be ignored.
Error in arcseconds = (3600) x (error in electrical degrees) / (disc line count)
- Interpolation Error* is present only when the resolution has been electronically increased to more than four data points per optical cycle. It is the sum of all the tolerances in the electronic interpolation circuitry.
Error in arcseconds = (1296000) x (error in quanta) / (counts/rev)
- With external Model HR2A High Resolution Electronics. Frequency response is as stated for output signals, or 50 kHz at the disc, whichever is limiting.



ELECTRICAL CONNECTIONS

EXTENDED RESOLUTION

The series 835S offers resolution up to 360,000 counts/rev (3.6 arcsec/count) after 4x quadrature edge detection. If finer resolution is required (up to 900,000 counts/rev, or 1.44 arcsec/count), the HR2A external electronics package provides a wide range of options that ensures compatibility with virtually all commercially available counter circuits, dedicated encoder interface cards and programmable logic controllers:

- Any number of quadrature square waves from 1 to 20 times the line count on the disc
- Fixed-duration pulses at 1, 2 or 4 times any integer from 1 to 20
- A choice of CW/CCW or PULSE/DIRECTION output pulse format
- A zero-index (reference) signal in either gated 1/2 cycle, gated 1/4 cycle, or fixed duration pulse format
- EIA/RS-422 or open collector line drivers
- On-board low-dropout voltage regulator

Refer to the HR2A data sheet for full details.

Wire Colors (Connector Code P)	Pin # MS3102E-18-1P (Connector Code M or A)	Buffered Sine Wave Output (Output Code B)	Square Wave Output (Output Code C, F, L, T)		Pulse Output (Output Code P)
			Connector Code M or P	Connector Code A	
Yellow	A	Sin	A	A	CW
Brown	B		\bar{A}	B	$\bar{C}W$
Green	C	Cos	B	IND	CCW
Orange	D		\bar{B}	+V	$\bar{C}C\bar{W}$
Blue	E	Index	IND		IND
White	F		$\bar{I}ND$	Common	$\bar{I}ND$
	G			Case	
Gray	H	Case	Case	\bar{A}	Case
Red	I	+V	+V	\bar{B}	+V
Black	J	Common	Common	$\bar{I}ND$	Common

Pin # DA-15P (Connector Code Q)	Pin # DE-9P (Connector Code S)	Buffered Sine Wave Output (Output Code B)	Square Wave Output (Output Code C, F, L, T)	Pulse Output (Output Code P)
1	6		$\bar{I}ND$	$\bar{I}ND$
2	2		IND	IND
4	7	+V	\bar{B}	CW
5	3	Index	B	CW
7	8		A	CCW
8	4	Case	A	CCW
9	1	Sin	Case	Case
10	5		+V	+V
11		Cos		
13	9		Common	Common
14			Shield	Shield
15		Common		

NOTES:

1. Channel B (Cos) leads Channel A (Sin) for CW shaft rotation, viewed from shaft end
2. A, B, and IND are provided with line driver outputs only (Output Code L).
3. Connector code S is not available with buffered sinusoid output
4. Shield is not connected at the encoder.

BEARING LIFE RATINGS/HOURS

Speed (rpm)	Radial Load at End of Shaft, Pounds			
	5	15	30	50
100	1,730,000	726,000	164,000	36,000
200	865,000	363,000	82,000	18,000
500	346,000	145,000	33,000	7,100
1,000	173,000	72,600	16,400	3,600
2,000	86,500	36,300	8,200	1,800
5,000	34,600	14,500	3,300	710
10,000	17,300	7,300	1,640	360

The table gives bearing life as a function of speed and radial load at the end of the shaft, based on fatigue failure criteria. In many long-duration applications, lubrication retention becomes the determining factor.

When high radial shaft loads are applied to an encoder with a high line count on the disc, the encoder may not meet the stated quadrature tolerance. Please consult the factory if your application requires this combination.

835S
PAGE 3 OF 6

V3.1

Gurley Precision Instruments
514 Fulton Street
Troy, NY 12180 U.S.A.
(800) 759-1844, (518) 272-6300, fax (518) 274-0336,
Online at www.gurley.com, e-mail: info@gurley.com



DIMENSIONS

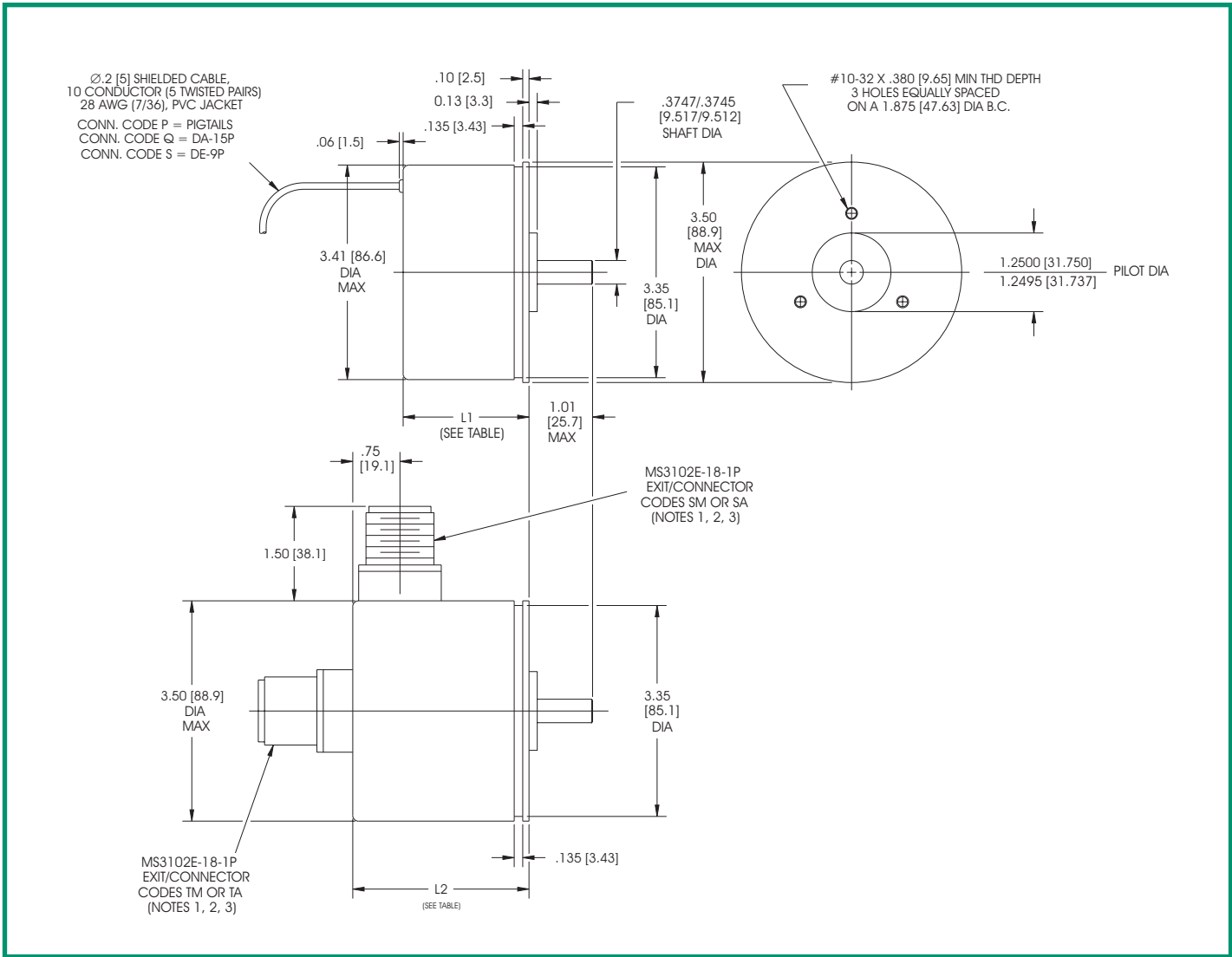

ENCODER LENGTH		
L1	L2	OUTPUT INTERP. CODES
2.30 [58.4]	2.45 [62.2]	B01, C01, F01, F02, L01, L02 T01, T02, P01, P02, P04, P08
2.65 [67.3]	2.80 [71.1]	L05, L08 P05, P10, P20

NOTES:

- Mating connector is optional. Order **M01** to mate with connector code **Q**, **M02** for connector code **A** or **M**, or **M06** for connector code **S**.
- With connector codes **P**, **Q** and **S**, the cover is drawn aluminum can. With connector code **M** and **A**, the cover is a rugged aluminum extrusion with an O-ring between the cover and the base.



POWER SUPPLY OPTIONS

$V_{cc} = +5.0 \text{ VDC} \pm 0.25 \text{ V} @ 225 \text{ mA max}$, or $V_{cc} = 7 \text{ to } 15 \text{ VDC} @ 225 \text{ mA}$ (available with power buffer or line driver options).

SINUSOIDAL OUTPUT

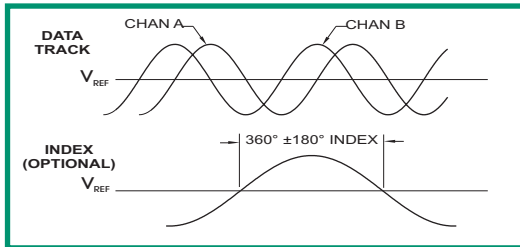

SINUSOIDAL OUTPUT OPTION

This option provides quadrature sinusoids at the same spatial frequency (cycles/rev) as the line count on the disc. At lower line counts, the signals tend to be more trapezoidal

BUFFERED SINUSOIDS

(OUT INTERP = B01)

The output device is an op amp referenced to $(50\% \pm 3\%) \times V_{cc}$. Typical signal values at 1 kHz with 4.7 kΩ load to ground (20°C).

- P-P signal amplitude, data channels: $1.0 \pm 0.1 \text{ V}$
- Amplitude ratio, min chan to max chan: .90 to 1.00
- P-P signal amplitude, index channel: $0.7 \pm 0.3 \text{ V}$

PULSE OUTPUT

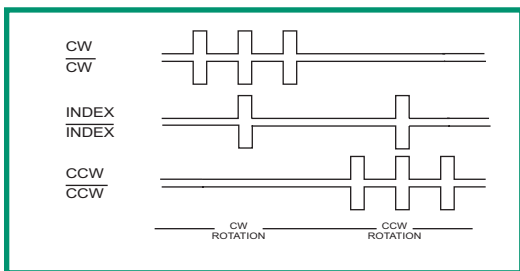

PULSE OUTPUT OPTIONS

All pulse outputs are direction-sensed (CW pulses and CCW pulses are on different terminals). The output device is an EIA/RS-422 balanced differential line driver protected to survive an extended-duration short circuit across its output. Pulse width is $0.4 \pm 0.1 \mu\text{s}$. The index pulse is gated so that it always occurs simultaneously with a specific data pulse. The maximum output pulse rate is 650 kHz, based on maintaining adequate separation between pulses; however, the frequency response of the square waves from which the pulses are generated is often the limiting factor in determining maximum encoder speed. Available with either 5 V or 7-15 V encoder power input.

1x, 2x, 4x or 8x PULSES

(OUT INTERP = P01, P02, P04 or P08)

Available on both models. Pulses are at 1, 2, 4 or 8 times the line count on the disc.

5x, 10x, or 20x PULSES

(OUT INTERP = P05, P10, or P20)

Available on Models 8235S only.

SQUARE WAVE OUTPUT

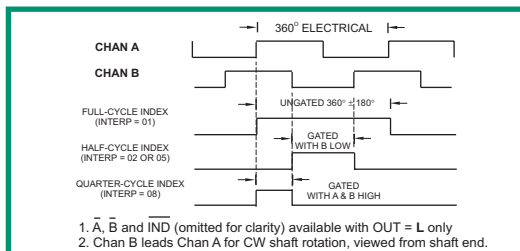

1. A, B and IND (omitted for clarity) available with OUT = L only
2. Chan B leads Chan A for CW shaft rotation, viewed from shaft end.

QUADRATURE SQUARE WAVE OUTPUT OPTIONS

1x or 2x Square Waves

Available on both models. Square waves are at the same or twice the spatial frequency (cycles/rev) as the disc line count.

5x or 8x Square Waves

Available on Model 8235S only. Square wave spatial frequency is five or eight times the disc line count.

1x SQUARE WAVES, TTL COMPATIBLE

(OUT INTERP = T01)

Output device is LM339 voltage comparator with internal 2.2kΩ pull-up resistor.

TTL Fanout = 5 $V_{OH} \geq V_{CC} - 0.25\text{V}$

$I_{SINK} = -8 \text{ mA}$ $V_{OL} \leq 0.8 \text{ V}$

2x SQUARE WAVES, TTL COMPATIBLE

(OUT INTERP = T02)

Output device is high-speed CMOS logic gate. Max rating:

$I_o \pm 25 \text{ mA}$ ($V_o = 0 \text{ to } V_{CC}$)

1x SQUARE WAVES,

OPEN COLLECTOR

(OUT INTERP = C01)

Output device is LM 339 voltage comparator with open collector output transistor. Outputs are pulled up to + 5 VDC with internal 10 kW resistor. Customer may provide external pull-up as desired, within rating of LM339.

$V_{COH} \leq + 36 \text{ V}$

$I_{COL} \leq 16 \text{ mA}$

1x, 2x, 5x OR 8x SQUARE WAVES, LINE DRIVER

(OUT INTERP = L01, L02, L05 or L08)

The output device is an EIA/RS-422 balanced differential line driver protected to survive an extended-duration short circuit across its output.

1x, 2x SQUARE WAVES, POWER BUFFER

(OUT INTERP = F01 or F02)

Output device is 2N3725 driver transistor. Outputs are pulled up to supply voltage with an internal 10 kW resistor. Customer may provide external pull-up as desired, within the range of the output device.

$V_{COH} \leq + 40 \text{ V}$

$I_{COL} \leq 200 \text{ mA}$

ORDERING INFORMATION

MODEL	LINES	IND	V	OUT	INTERP -	BASE	CAB	EXIT	CONN	06E	SPEC

MODEL

8135S Standard accuracy
8235S High accuracy

LINES - Disc line count

00360	00500	00512	00900	01000
01024	01575	01800	02000	02048
02500	02540	02700	03000	03175
03300	03600	04000	04050	04096
04200	04302	04310	04500	05000
05400	06000	06400	06480	07000
07200	07640	08000	08192	09000
09550	09900	10000	10800	11250

Consult factory for other line counts

IND - Index format

F Full cycle ungated (INTERP = **01**)
H Half cycle gated (INTERP = **02, 05**)
Q Quarter cycle gated (INTERP = **08**)
P Pulse index (OUT = **P**)
N None

V - Input voltage

5 5 volts dc
R 7-15 volts dc (OUT = **F, L** or **P**)

OUT output format

B Buffered sinusoids (INTERP = **01**)
C Open collector (single-ended sq. waves)
 (INTERP = **01**)
F Power Buffer (single-ended sq. waves)
 (INTERP = **01, 02**)
L RS-422 differential line driver
 (INTERP = **01, 02, 05, 08**)
T Single-ended TTL (INTERP = **01, 02**)
P Pulses (cw and ccw)
 (INTERP = **01, 02, 04, 05, 08, 10, 20**)

INTERP - Interpolation factor

01 With buff. sinusoid output
01, 02, 05, 08 With square wave output
01, 02, 04, 05, 08, 10, 20 With pulse output

BASE - Base type

A Synchro/face mount

CAB - Cable length, inches (04-99)

18 Standard
00 With CONN code **M** or **A**

EXIT Cable exit or connector location

S Side (CONN = **M** or **A**)
T Top (CONN = **P, Q, S, M** or **A**)

CONN - Connector

P Pigtails (no connector) (EXIT = **T**)
Q DA-15P (EXIT = **T**)
M MS3102E-18-1P (see wiring table)
A MS3102E-18-1P (see wiring table)
S DE-9P (EXIT = **T**)

SPEC - Special code

X To define non-standard features
N No special features

Accessories (order separately)

SCA-06E-XXE or **M** Shaft coupling
 (see separate data sheet)

AX06399 Synchro cleats
 (see separate data sheet)

M01 Mating connector for DA-15P
M02 Mating connector for MS3102E-18-1P
M06 Mating connector for DE-9P
ISC3N Interface card for IBM[®] PC

SPECIAL CAPABILITIES

For special situations, we can optimize catalog encoders to provide higher frequency response, greater accuracy, wider temperature range, reduced torque, non-standard line counts, or other modified parameters. In addition, we regularly design and manufacture custom encoders for user-specific requirements. These range from high-volume, low-cost, limited-performance commercial applications to encoders for military, aerospace and similar high-performance, high-reliability conditions. We would welcome the opportunity to help you with your encoder needs.

WARRANTY

Gurley Precision Instruments offers a limited warranty against defects in material and workmanship for a period of one year from the date of shipment.

835S

PAGE 6 OF 6

V3.1

Gurley Precision Instruments
 514 Fulton Street
 Troy, NY 12180 U.S.A.

(800) 759-1844, (518) 272-6300, fax (518) 274-0336,
 Online at www.gurley.com, e-mail: info@gurley.com

