

GURLEY SERIES 8X60 ANGLE ENCODER

MOTION TYPE:

ROTARY

USAGE GRADE:

INDUSTRIAL METROLOGY

OUTPUT:

INCREMENTAL

MAX RESOLUTION:

**0.000078°
(0.28 ARCSEC)**



VERY HIGH RESOLUTION - INDUSTRIAL RUGGEDNESS

The Series 8X60 is a robust metrology-grade encoder that is equally well-suited for industrial applications. It incorporates four reading heads to eliminate many common sources of encoder errors, while its stainless steel construction greatly enhances resistance to shock and vibration.

It is designed for very precise positioning of rotary tables on machine tools, coordinate measuring machines, dividing apparatus, antennas, test equipment and similar devices.

The 8X60 incorporates an internal ASIC (application-specific integrated circuit) to generate quadrature square waves up to 64 times the line count on the disc. Thus, the resolution (after 4X quadrature evaluation by the user) can be as fine as 0.28 arcsec (0.000078°, or 4,608,000 counts per revolution).

The 8X60 is available in both shafted and hollow shaft versions, and is interchangeable with common competitive products. It comes in two accuracy grades:

**8460: ± 2 arcseconds accuracy
8560: ± 1.25 arcseconds accuracy**

**ISO
9001
CERTIFIED**

Gurley Precision Instruments
514 Fulton Street
Troy, NY 12180 U.S.A.
(800) 759-1844, (518) 272-6300, fax (518) 274-0336,
Online at www.gurley.com, e-mail: info@gurley.com



ingenuity[®]@work

SPECIFICATIONS

MODEL	8460H	8460S	8560S
Input Power	+5 VDC +/- 5%, 150 mA max		
Available line counts	12960, 15000, 16384 and 18000		
Output waveforms Data Index Fault detection signal	Quadrature square waves ¼-cycle wide, gated with high states of A and B Active low pulse indicates out-of-tolerance encoder operation		
Maximum resolution (after user's 4X quadrature decode)	0.00007° (0.28 arcsec) with 64X interpolation 0.0001° (0.36 arcsec) with 50X interpolation 0.00015° (0.56 arcsec) with 32X interpolation 0.0002° (0.72 arcsec) with 25X interpolation 0.0003° (1.125 arcsec) with 16X interpolation 0.0005° (1.80 arcsec) with 10X interpolation 0.0006° (2.25 arcsec) with 8X interpolation 0.001° (3.60 arcsec) with 5X interpolation 0.0012° (4.50 arcsec) with 4X interpolation 0.0025° (9 arcsec) with 2X interpolation 0.005° (18.0 arcsec) with 1X interpolation		
Output device	EIA/RS-422 differential line drivers (TTL compatible) on all channels		
Accuracy at 20° C	+/- 2.0 arcsec	+/- 1.25 arcsec	
Maximum output frequency	3 MHz (with 50X interpolation)		
Maximum weight, kg [lb]	3.8 [8.4]	3.5 [7.7]	
Starting torque at 20°C Nm [in-oz]	0.5 [75]	0.012 [1.8]	
Moment of inertia g-cm ² [in-oz-s ²]	1700 [0.24]	3140 [0.44]	
Maximum shaft load	N/A	30 N [7 lb] (axial or radial)	
Protection level	IP64		
Operating temperature	0°C to 50°C [32°F to 122°F]		
Maximum mech. speed	1000 RPM		

USING THE 8X60

In order to have a system that does not miss any counts during the 4X quadrature evaluation, user's counter or input circuit must be able to detect quadrature edges as close as 50 nanoseconds, which corresponds to a 20 MHz count rate.

WATCHDOG CIRCUIT

A fault-detection circuit constantly monitors the encoder's internal signals . If they deviate beyond prescribed limits, an active-low signal is generated.

Fault conditions detectable by this circuit include:

- LED light source failure or aging
- Defective photo-detectors
- Contamination of the code disc or other optical components
- Localized code disc defects such as chips or cracks



Gurley Precision Instruments
514 Fulton Street
Troy, NY 12180 U.S.A.
(800) 759-1844, (518) 272-6300, fax (518) 274-0336,
Online at www.gurley.com, e-mail: info@gurley.com



SPECIFICATIONS

SHAFT COUPLING

The Model 8460H incorporates an internal coupling that easily clamps to the user's shaft; it does not require threads, precise shoulders or other special machining.

To take full advantage of the inherent accuracy of the Model 8X60S, we recommend that either the SCB-14MN or SCC-14MN shaft coupling be used to connect the encoder shaft to the user's shaft or rotary table.

COUPLING SPECIFICATIONS		SCB-14MN	SCC-14MN
Kinematic accuracy	± 0.5 arcsec ⁽¹⁾		
Torsional rigidity, N-m/rad [in-oz/arcsec]	6000 [4.1]	4000 [2.7]	
Maximum parallel offset, mm [in]	0.3 [0.012]	0.5 [0.020]	
Max. axial extension or comp., mm [in]	0.1 [0.004]	0.5 [0.020]	
Maximum angular misalignment	0.2°	2.0°	
Moment of inertia (approximate) g cm ² [in-oz-s ²]	2000 [0.028]		

OUTPUT SIGNALS

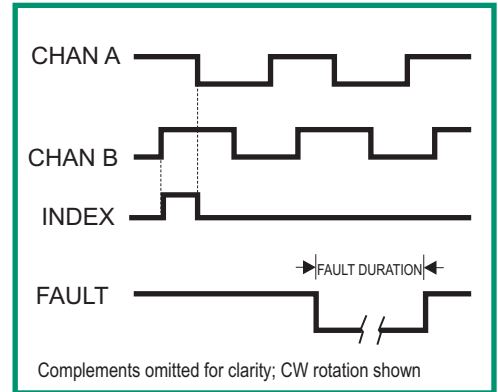

- NOTES:**
1. With parallel offset ≤ 0.05 mm and angular misalignment $\leq 0.03^\circ$
 2. Weight in grams [lbs] is 190 [0.42]
 3. Clamping screw torque, N-M [in-lb] is 1 [9]

8X60S DIMENSIONS

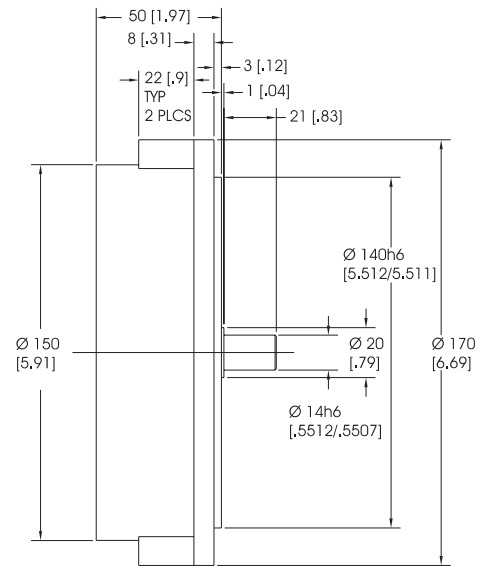
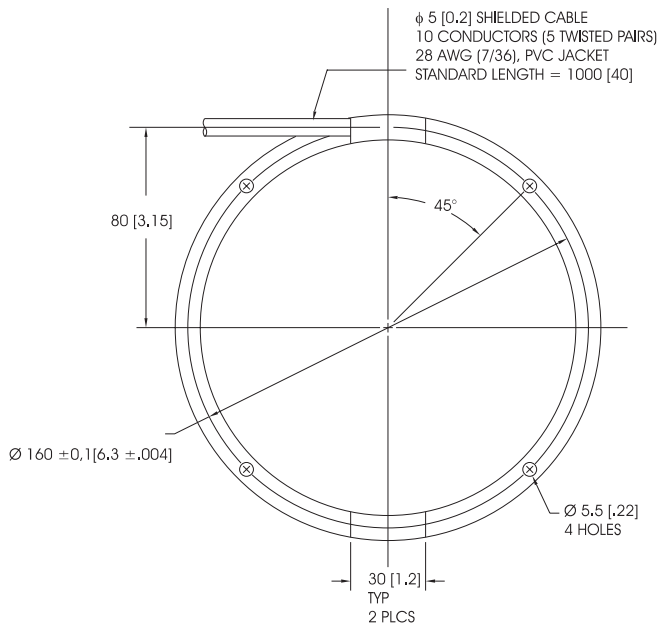

ALL DIMENSIONS IN mm [in]

8X60S

PAGE 3 OF 6

V3.1

Gurley Precision Instruments
 514 Fulton Street
 Troy, NY 12180 U.S.A.
 (800) 759-1844, (518) 272-6300, fax (518) 274-0336,
 Online at www.gurley.com, e-mail: info@gurley.com



Model 8460H

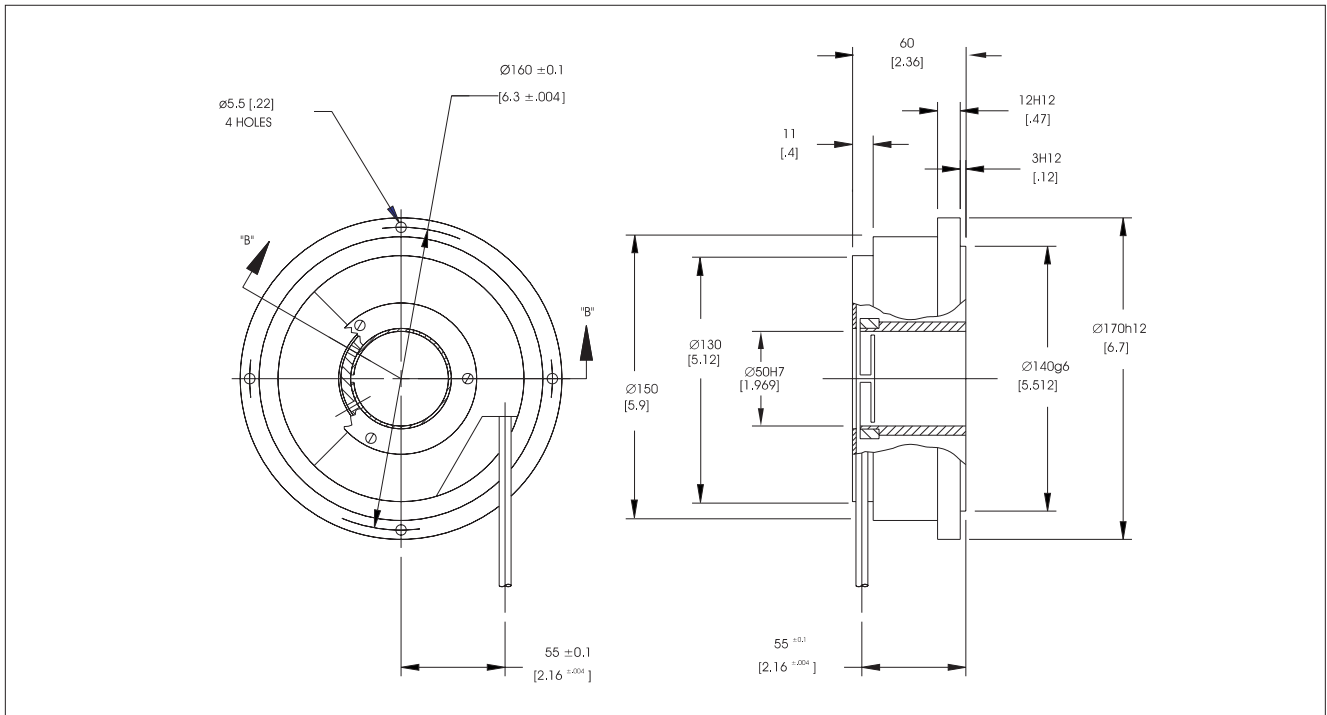

User's Mounting Dimensions

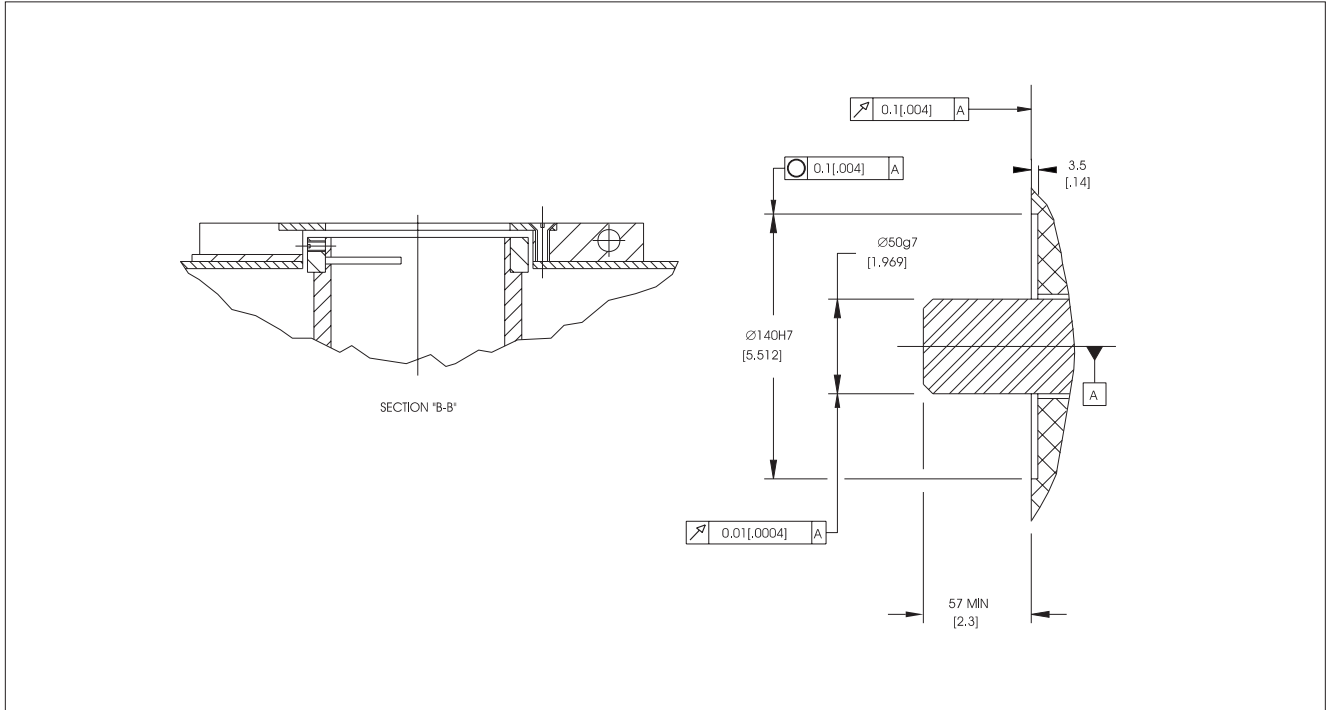

ALL DIMENSIONS IN mm [in]

ORDERING INFORMATION

MODEL **SHAFT** **LINES** **IND** **VOLT** **OUT** **INTERP.** **BASE** **CABLE** **EXIT** **CONN** **SHAFT** **SPEC**
 Q 5 L A S

MODEL

8460 ± 2 ARCS ACCURACY
8560 ± 1.25 ARCS ACCURACY

SHAFT

S SOLID SHAFT
H HOLLOW SHAFT
(8460 ONLY)

LINE COUNT

12960, 15000, 16384, 18000

INDEX

Q Quarter cycle

VOLTAGE

5 +5 volts dc

OUTPUT FORMAT

L RS-422 differential line driver

INTERPOLATION FACTOR

1X, 2X, 4X, 8X, 10X, 16X,
25X, 32X, 50X or 64X

BASE

A Synchro/face mount

CABLE LENGTH

XX INCHES
40 STANDARD

EXIT

S Side

CONNECTOR

P PIGTAILS
Q DA - 15P
S DE-9P (FLT and /FLT not available)

SHAFT

14M SOLID SHAFT
50M HOLLOW-SHAFT

SPECIAL CODE TO DEFINE NON-STANDARD FEATURES

N NO SPECIAL FEATURE

OPTIONS

SCB-14MN SHAFT COUPLING
SCC-14MN SHAFT COUPLING
M01 MATING CONNECTOR FOR DA-15P
M06 MATING CONNECTOR FOR DE-9P

ELECTRICAL CONNECTIONS

CONN. CODE	P	Q	S
CONN. TYPE	NONE	DA-15P	DE-9P
FUNCTION	COLOR	PIN #	PIN #
A	Yellow	8	4
/A	Brown	7	8
B	Green	5	3
/B	Orange	4	7
IND	Blue	2	2
/IND	White	1	6
+V	Red	10	5
COMMON	Black	13	9
CASE	Drain	9	1
FAULT	Violet	12	N/A
/FAULT	Gray	11	N/A
MATING CONN.	-	M01	M06

SPECIAL CAPABILITIES

For special situations, we can optimize catalog encoders to provide higher frequency response, greater accuracy, wider temperature range, reduced torque, non-standard line counts, or other modified characteristics. In addition, we regularly design and manufacture custom encoders for user-specific requirements. These range from high-volume, low-cost, limited-performance commercial applications to encoders for military, aerospace and similar high-performance, high-reliability conditions. We would welcome the opportunity to help you with your encoder needs.

WARRANTY

Gurley Precision Instruments offers a limited warranty against defects in material and workmanship for a period of one year from the date of shipment.

