

GURLEY MODEL 9710 MODULAR INCREMENTAL ENCODER

MOTION TYPE:

ROTARY

USAGE GRADE:

PROTECTED INDUSTRIAL

OUTPUT:

INCREMENTAL

*MAX RESOLUTION:

1.5 ARCS

*W/EXTERNAL ELECTRONICS



- MANY DISC SIZES
- FRICTION FREE OPERATION
- VACUUM-COMPATIBLE OPTION

The **Model 9710** is a versatile rotary incremental encoder. Its modular construction provides friction-free operation, and the wide selection of disc sizes affords the design engineer great flexibility.

When used with the optional **HR2B** or **HR2C** interpolator, its optical resolution can be electronically increased and the output provided as quadrature square waves plus index from RS422 differential line drivers.

For absolute positioning in a modular encoder, please refer to the **9710VA** (rotary and linear) or **7700** (rotary in a compact package) datasheets

ingenuity[®]@work

ISO
9001
CERTIFIED

Gurley Precision Instruments
514 Fulton Street
Troy, NY 12180 U.S.A.
(800) 759-1844, (518) 272-6300, fax (518) 274-0336,
Online at www.gurley.com, e-mail: info@gurley.com



SPECIFICATIONS

Electrical	
Input Power	V_{CC} : +5VDC 0.25 VDC@ 10 mA I_{LED} : +20mA regulated DC current source
Light Source	Screened infra-red LED; rated life > 100,000 hours
Output Signals	High-output differential Sine, Cosine, and Index photocurrents. Signal levels are designed for proper operation with GPI's HR2B or HR2C electronics packages. Consult factory to establish criteria for waveforms when 9710 is used with other electronics.
Mechanical	
Materials Encoder Body Scale of Disk	Aluminum Vacuum-deposited chrome pattern on glass
Weight Read Head Scale	1.7 oz (49g) + cable @ 0.034 oz/in (0.04 g/mm) 0.09 lb/in ³ (2.5 x 10 ⁻² g/mm ³)
Performance	
Frequency Response	50 kHz, all channels (Max. Speed may be limited by subsequent electronics; see data sheet for HR2B and HR2C interpolators.)
Quadrature Error	$\pm 30^\circ$ typical (depends on user's installation)
Scale Accuracy Standard Optional	± 0.0001 in/ft (8 μ m/m) ± 0.00005 in/ft (4 μ m/m)
Disc Accuracy Dia ≤ 3 " Dia > 3"	± 10 arcs ± 5 arcs
Environmental	
Operating Temp. Humidity Shock Vibration	-40° F to +185° F (-40° C to +85° C) 98% rh, non-condensing 50g, 11 ms 2g, 0-2000 Hz

As part of our continuing product improvement program, all specifications are subject to change without notice.



SPECIFICATIONS

DIGITAL OUTPUT AND EXTENDED RESOLUTION

The Model **9710** provides phototransistor output as unbuffered sinusoids. For digital output signals or extended resolution, our Models **HR2B** and **HR2C** electronics packages transmit quadrature square waves, gated index, and built-in "watchdog" self-test data via RS-422 differential line drivers. Output square waves are at 20 times the line count on the disc with the **HR2B**, or at 1, 2, 3, 4, 5, 8, 10, 12, 16 or 25 times the line count with the **HR2C**. Please refer to the **HR2B/HR2C** data sheet for full details.

DISCS

Gurley does not offer disc hubs as catalog items, but we will mount discs to customer-furnished hubs, and we can provide hubs designed for your specific application. Even if we are not providing the mounting or the hub, we strongly suggest that you consult with us regarding the proper design of the disc/hub assembly and mounting of the **9710** Read Head.

All dimensions are in inches (mm). Consult factory for other line counts or sizes.

O.D.	I.D.	Thick	#Lines *	Throat	CL-Mntg	P/N
3.16 (80.264)	1.54 (39.116)	0.065 (1.651)	5000 R	0.125 (1.955)	1.955 (49.657)	CX01323
3.90 (99.060)	2.10 (53.340)	0.125 (3.175)	2048 R	0.062 (2.262)	2.262 (57.455)	CX01225
4.80 (121.920)	2.90 (73.660)	0.120 (3.200)	2048 R	0.105 (2.775)	2.775 (70.485)	CX01305
5.30 (134.620)	3.50 (88.900)	0.120 (3.200)	6000 R	0.063 (2.963)	2.963 (75.260)	CX01325
5.45 (138.430)	3.50 (88.900)	0.235 (5.969)	8192 R	0.062 (2.262)	3.037 (77.140)	CX01331
5.45 (138.430)	3.70 (93.980)	0.235 (5.969)	8192 R	0.062 (2.262)	3.037 (77.140)	CX01347
7.00 (177.800)	4.80 (121.920)	0.235 (5.969)	9000 R	0.063 (2.963)	3.813 (96.850)	CX01339
9.00 (228.600)	6.00 (152.400)	0.235 (5.969)	9000 R	0.062 (2.262)	4.812 (122.225)	CX01300
9.00 (228.600)	6.00 (152.400)	0.235 (5.969)	10800 R	0.062 (2.262)	4.812 (122.225)	CX01290
16.00 (406.400)	13.25 (336.550)	0.235 (5.969)	9000 R	0.062 (2.262)	8.312 (211.125)	CX01297
16.25 (412.780)	14.00 (355.600)	0.235 (5.969)	6000 S	N/A	6.650 (168.910)	CX01157
23.00 (584.200)	20.25 (514.350)	0.235 (5.969)	9000 S	N/A	9.775 (248.285)	CX01270

* **R** means read head straddles disc O.D.; this is the preferred method.

S means read head straddles disc I.D.; consult factory.



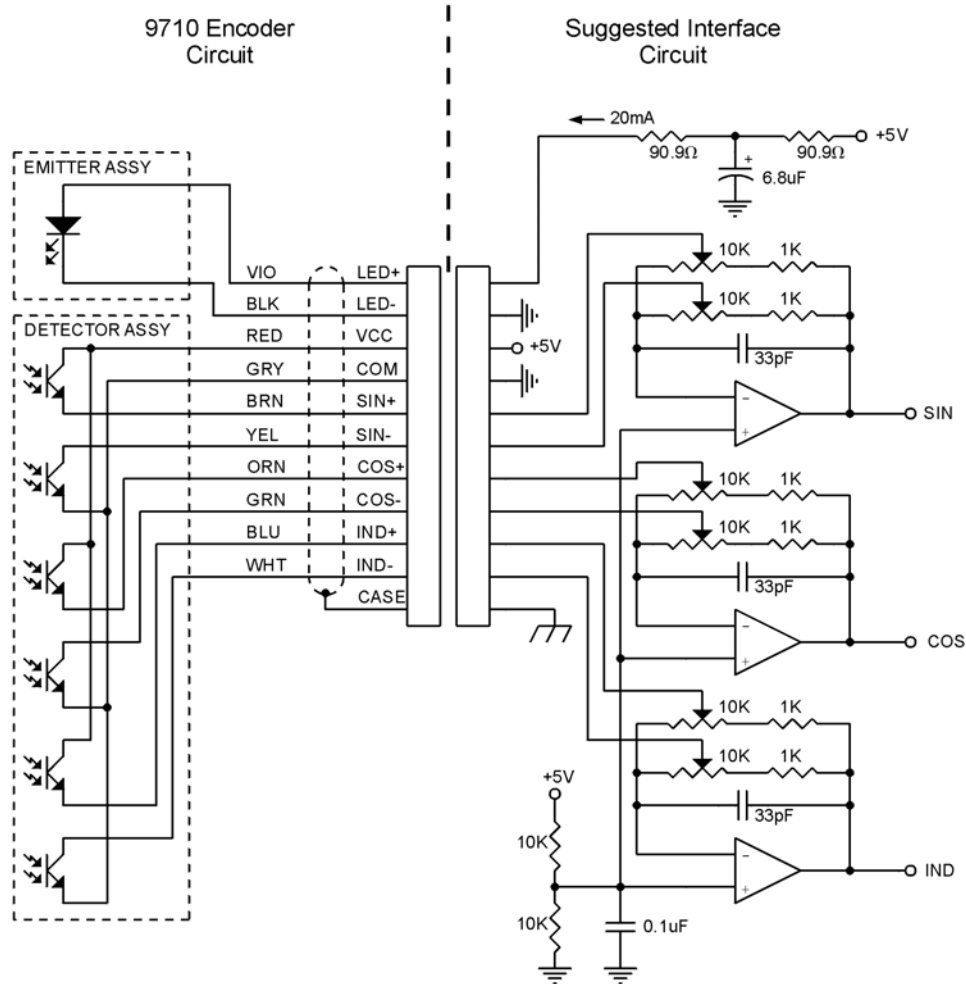

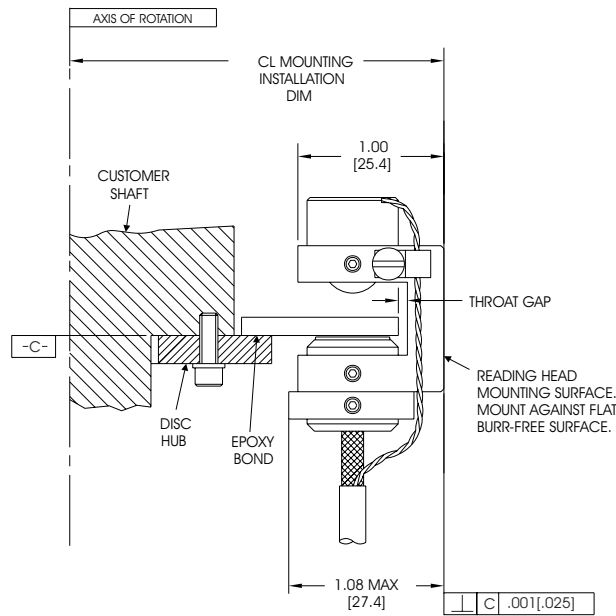
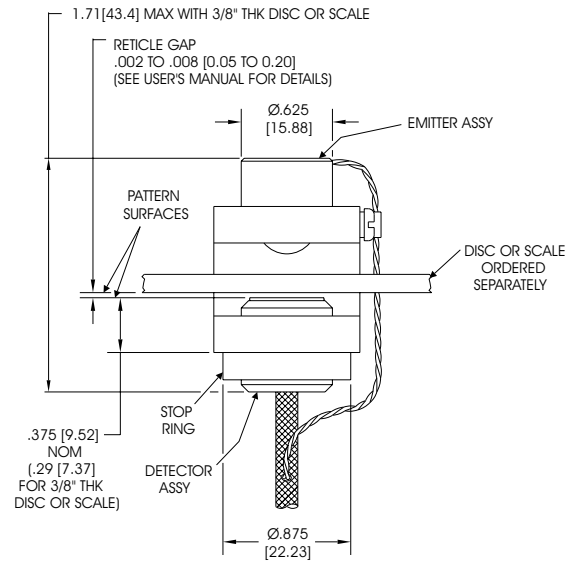
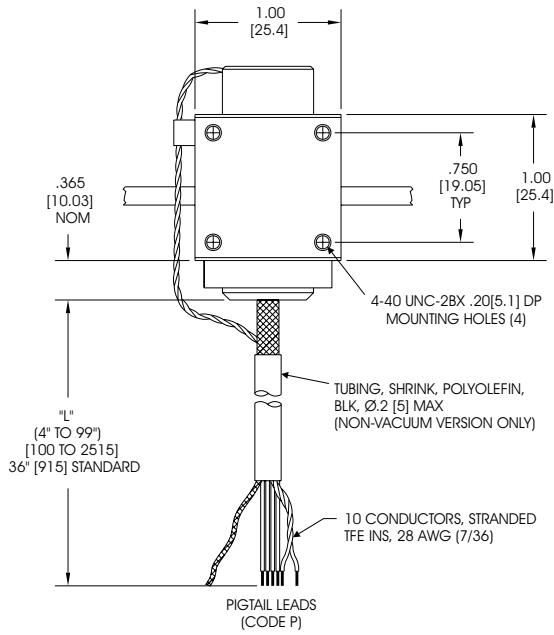

SUGGESTED MOUNTING METHOD

ORDERING INFORMATION

	ENV	LINES	TYPE	IND	LENGTH	CONN	DIA	SF
9710								

- | | | |
|---------------|------------------------|---|
| ENV | S
V | Standard environment
Vacuum-compatible |
| LINES | ##### | Lines/rev. Add leading zeroes for 5 digits total. |
| TYPE | R
S | Rotary with head straddling the O.D.
Rotary with head on the I.D. (consult factory) |
| INDEX | M
S | Mesh aperture - use with fine incremental (>245 L/in \approx 10 L/mm)
Single aperture - use with coarse incremental (\leq 245 L/in) |
| LENGTH | ##
36 | Cable length in inches (04-99)
Standard |
| CONN | P
S | Pigtails (no connector)
DE-9P (use with HR2B or HR2C electronics) |
| DIA | #### | Disc O.D. (if TYPE = R), or disc I.D. (if TYPE = S). Diameter in inches, to the nearest 0.01", with no decimal point; example: 0390 = 3.90". Add leading zeroes for 4 digits total. |
| SF | #
N | Issued at time of order to cover special customer requirements
No special features |

Specify disc separately

Options and accessories

- | | |
|--------------|--|
| HR2B | Incremental interpolator (20X). See HR2B/HR2C data sheet |
| HR2C | Incremental interpolator (1, 2, 3, 4, 5, 8, 10, 12, 16, or 25X). See HR2B/HR2C data sheet |
| M06 | Mating connector for DE-9P |
| ISC3N | PC Interface card |

SPECIAL CAPABILITIES

For special situations, we can optimize encoders to provide higher frequency response, greater accuracy, wider temperature range, reduced torque, non-standard line counts, or other modified characteristics. In addition, we regularly design and manufacture custom encoders for user-specific requirements. These range from high-volume, low-cost, limited-performance commercial applications to encoders for high-performance, high-reliability conditions. We welcome the opportunity to help you with your special encoder needs.

WARRANTY

Gurley Precision Instruments offers a limited warranty against defects in material and workmanship for a period of one year from the date of shipment.

