

GURLEY MODELS R119 AND R120 ROTARY INCREMENTAL MINI-ENCODERS

MOTION TYPE:

ROTARY

USAGE GRADE:

LIGHT INDUSTRIAL

OUTPUT:

INCREMENTAL

MAX RESOLUTION:

65,536 COUNTS/REV



MINIATURE HIGH-RESOLUTION ENCODER

The Models **R119** and **R120** optical incremental encoders are designed for light industrial applications that require high resolution in a very small package. The two models share these features:

- Represent either shafted or blind-hollow shaft version
- LED illumination for long life (>100,000 hours)
- Differential photo-detectors for signal stability
- Single-board, surface-mount electronics for reliability
- RS-422 differential line driver output for noise immunity
- Zero index signal
- Monolithic integrated ASIC for internally interpolated resolutions up to 16,384 cycles/rev (65,536 counts/rev)

R119: ϕ 19-mm body; ribbon cable

R120: ϕ 20-mm body; round cable with shielded twisted pairs

ingenuity[®]@work

ISO
9001
CERTIFIED

Gurley Precision Instruments
514 Fulton Street
Troy, NY 12180 U.S.A.
(800) 759-1844, (518) 272-6300, fax (518) 274-0336,
Online at www.gurley.com, e-mail: info@gurley.com



SPECIFICATIONS

	See Note	Models R119 and R120
Maximum line count on disc		1024
Maximum cycles /rev (quad sq waves)		16,384
Max counts/rev (after quad decode)		65,536
Internal square wave interpolation		1x, 2x, 5x, 10x, or 16x
Instrument error, \pm arcminutes	1, 2	4
Quadrature error, \pm electrical degrees	1, 3	24
Interpolation error, \pm quanta	1, 4	0.15
Maximum output frequency, kHz		
1x square waves		100
2x square waves		150
5x square waves		300
10x, 16x square waves		500
Starting torque, in-oz (N-m) @20°C		0.07 (5 x 10 ⁻⁴)
Running torque, in-oz (N-m) @20°C		0.04 (2.9 x 10 ⁻⁴)
Moment of inertia, in-oz-s ² (g-cm ²)		5.7x 10 ⁻⁶ (0.4)
Maximum weight, oz (g)		1 (30)
Sealing		IP50
Max. Radial or axial shaft load, lb (N)	5	0.7 (3)
Bearing life with 0.25 lb radial load	6	1 x 10 ¹⁰ rev
Operating temperature, °F (°C)		32 to 158 (0 to 70)
Storage temperature, °F(°C)		-22 to 185 (-30 to 85)
Humidity, % rh, non-condensing		98
Shock		30g (300m/s ²)
Vibration		10g (100m/s ²)

Notes:

1. Total Optical Encoder Error is the algebraic sum of *Instrument Error* + *Quadrature Error* + *Interpolation Error*. Typically, these error sources sum to a value less than the theoretical maximum. Error is defined at the signal transitions and therefore does not include quantization error, which is $\pm 1/2$ quantum. ("Quantum" is the final resolution of the encoder, after user's 4X quadrature decode.) Accuracy is guaranteed at 20°C.
2. *Instrument Error* is the sum of disc pattern errors, disc eccentricity, bearing runout and other mechanical imperfections within the encoder. This error tends to vary slowly around a revolution.
3. *Quadrature Error* is the combined effect of phasing and duty cycle tolerances and other variables in the basic analog signals. This error applies to data taken at all four transitions within a cycle; if data are extracted from 1X square waves on a 1X basis (i.e., at only one transition per cycle), this error can be ignored.

Error in arcminutes = (60) x (error in electrical degrees) (disc line count)

4. *Interpolation Error* is present only when the resolution has been electronically increased to more than four data points per optical cycle. It is the sum of all the tolerances in the electronic interpolation circuitry.

Error in arcminutes = (21600) x (error in quanta) (counts/rev)

5. The maximum recommended shaft load is based on bearing life considerations. If accuracy is critical, shaft loads should be kept as low as possible.
6. Bearing life is based on fatigue failure criteria. In many long-duration applications, lubrication retention becomes the determining factor.

As part of our continuing product improvement program, all specifications are subject to change without notice



SPECIFICATIONS

INPUT POWER

+5 VDC ± 0.25 V @100 mA max.

SQUARE WAVE OUTPUT

Quadrature square waves at 1, 2, 5, 10, or 16 times the line count on the disc. On all channels: EIA/RS-422 balanced differential line driver, protected to survive an extended-duration short circuit across its output. May be used single-ended for TTL-compatible inputs. Index is 1/4-cycle wide, gated with the high states of channels A and B.

OUTPUT WAVEFORMS (CW rotation shown)

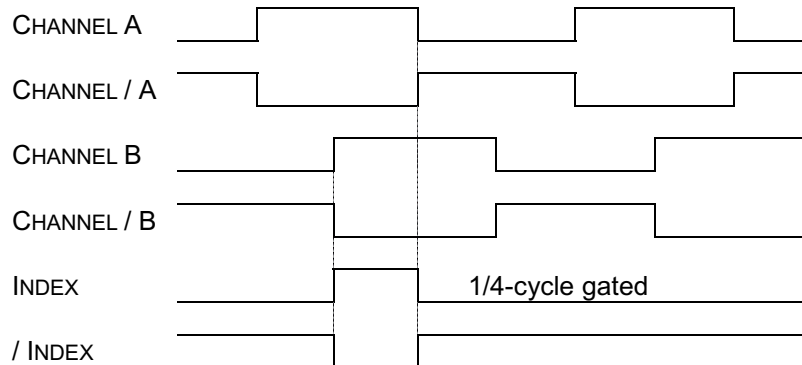

ELECTRICAL CONNECTIONS

Output Functions	R119		R120	
	Wire Colors Conn. Code P	Ribbon conn Conn. Code Y	Wire Colors Conn. Code P	Ribbon conn Conn. Code Y
A	Orange	2	Yellow	4
/ A	Yellow	3	Brown	8
B	Violet	6	Green	3
/ B	Gray	7	Orange	7
IND	Green	4	Blue	2
/ IND	Blue	5	White	6
+V	Red	1	Red	5
COMMON	White	8	Black	9
CASE			Bare (shield)	1

NOTE: Channel A leads Channel B for clockwise rotation, looking at the shaft end.

FLEXIBLE SHAFT COUPLINGS

	Tether Mount for -B version	SCD Coupling for -S version
Maximum parallel offset, in (mm)	0.002 (.05)	0.008 (0.2)
Maximum axial extension or compression, in (mm)	0.008 (0.2)	0.008 (0.2)
Maximum angular misalignment, degrees	2.0	0.5

See separate data sheet for specifications and ordering information for the Model **SCD** coupling.

NOTE: Flexible couplings are intended to absorb normal installation misalignments and run-outs in order to prevent undue loading of the encoder bearings. To realize all the accuracy inherent in the encoder, the user should minimize misalignments as much as possible.



R 1 1 9 DIMENSIONS

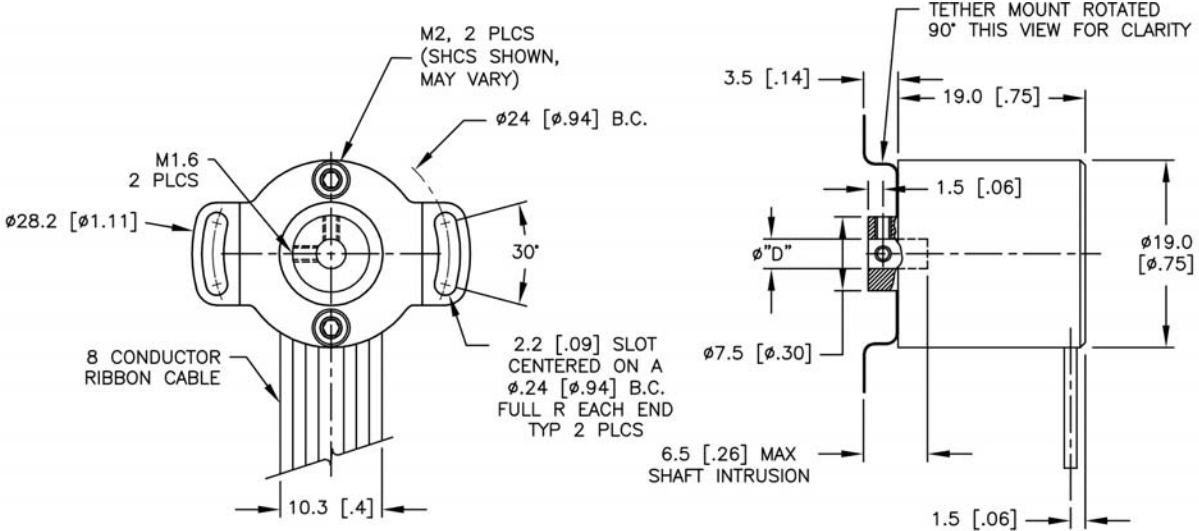

R119B (BASE CODE A)

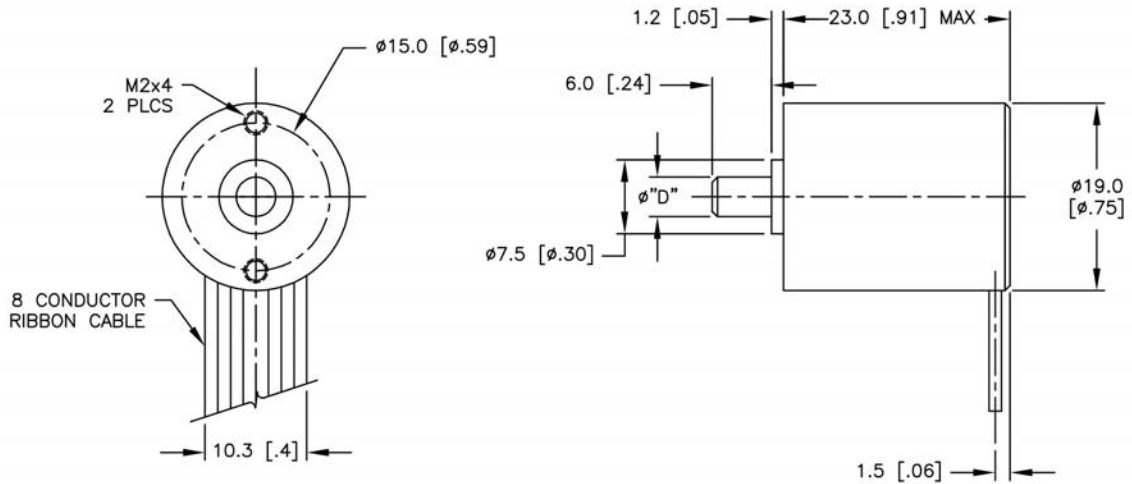

R119S (BASE CODE B)

$\phi "D"$ TABLE		
"DIA" CODE	R119S	R119B
04M	$\phi 4\text{mm h6}$	N/A
03M	$\phi 3\text{mm h6}$	$\phi 3\text{mm H7}$
02E	$\phi 0.125^{+0.0000}_{-0.0003}$	$\phi 0.125^{+0.0005}_{-0.0000}$

R120 DIMENSIONS

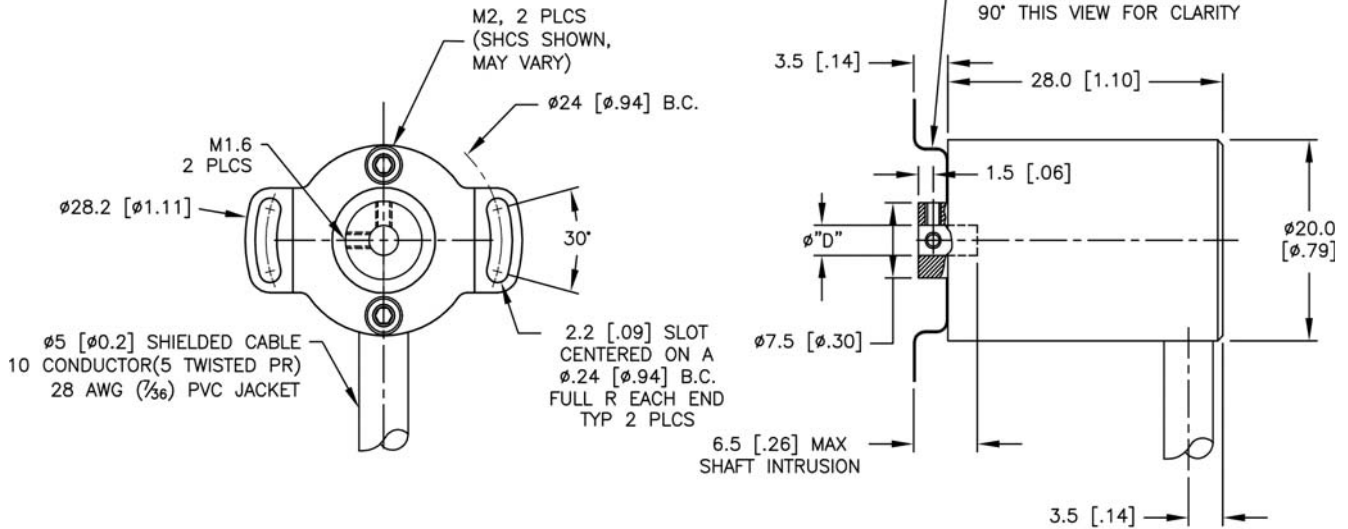

R120B (BASE CODE A)

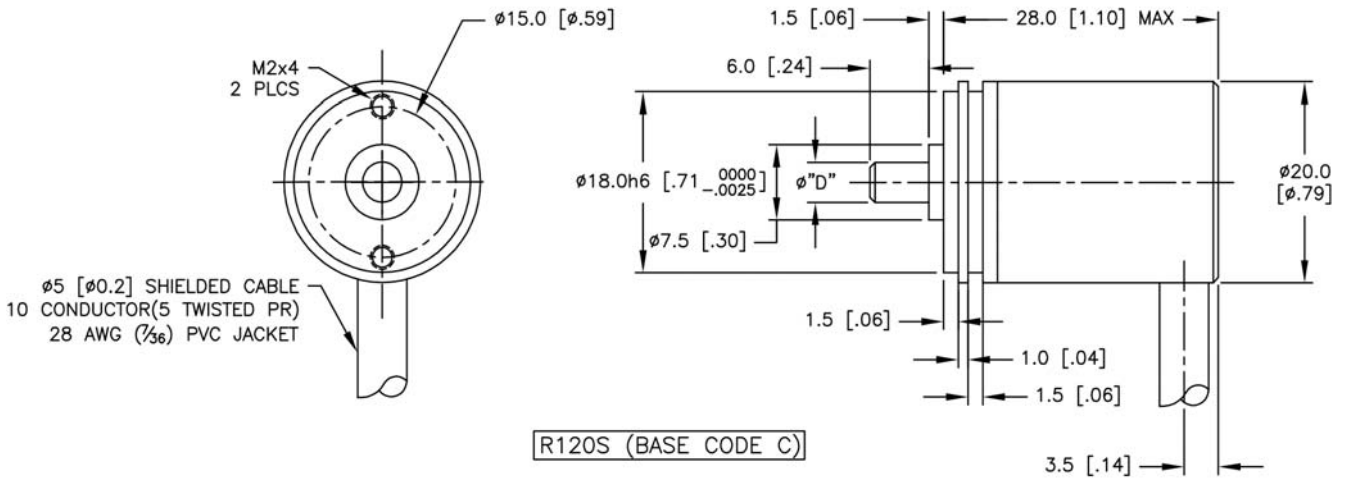

R120S (BASE CODE C)

"D" TABLE		
"DIA" CODE	R120S	R120B
04M	$\phi 4\text{mm h6}$	N/A
03M	$\phi 3\text{mm h6}$	$\phi 3\text{mm H7}$
02E	$\phi 0.125^{+.0000}_{-.0003}$	$\phi 0.125^{+.0005}_{-.0000}$

ORDERING INFORMATION

MODEL	SHAFT	LINES	IND	OUT	INTERP	BASE	CAB	EXIT	CONN	DIA	SPEC
				5							

MODEL

R119 ϕ 19-mm body, ribbon cable
R120 ϕ 20-mm body, round cable

SHAFT

B Blind hollow shaft
S Solid shaft

LINES - Disc line count

00360, 00500, 00512, 00900, 01000, 01024
Consult factory for other line counts

IND - Index format

Q Quarter-cycle gated index

V - Input voltage

5 +5 Vdc

OUT - Output format

L RS422 differential line driver

INTERP - Interpolation factor

01, 02, 05, 10, 16

BASE

A Use with **R119B** or **R120B**
B Use with **R119S**
C Use with **R120S**

CAB - Cable length, inches

18 Standard

EXIT

S Side-exit cable

CONN - Connector

P Pigtails (no connector)
Y 8-pos ribbon cable socket connector
 (Berg 71602-308 or equal) (**R119** only)
S DE-9P (**R120** only)

DIA - Shaft diameter

02E 1/8" (SHAFT = **S** or **B**)
03M 3 mm (SHAFT = **S** or **B**)
04M 4 mm (SHAFT = **S**)

SPEC- Special features

Issued at time of order to cover special customer requirements
N No special features

ACCESSORIES (order separately)

SCD-xxx-xxx Shaft coupling (see separate data sheet)
M06 Mating connector for DE-9P

SPECIAL CAPABILITIES

For special situations, we can optimize catalog encoders to provide higher frequency response, greater accuracy, wider temperature range, reduced torque, non-standard line counts, or other modified characteristics. In addition, we regularly design and manufacture custom encoders for user-specific requirements. These range from high-volume, low-cost, limited-performance commercial applications to encoders for military, aerospace and similar high-performance, high-reliability conditions. We would welcome the opportunity to help you with your encoder needs.

WARRANTY

Gurley Precision Instruments offers a limited warranty against defects in material and workmanship for a period of one year from the date of shipment.

