

GURLEY SERIES VX35H VIRTUAL ABSOLUTE ENCODER

MOTION TYPE:

ROTARY

USAGE GRADE:

INDUSTRIAL

OUTPUT:

ABSOLUTE

MAX RESOLUTION:

2^{20} (1,048,576) STEPS/REV
(W/ SEPARATE ELECTRONICS)



BUILT IN TESTING - ABSOLUTE OUTPUT

The **Series Vx35H** combines the opto-mechanical simplicity and ruggedness of an incremental encoder with the system reliability and interfacing ease of an absolute encoder. Utilizing Gurley's unique **Virtual Absolute** technology, the **Vx35H** is less expensive and more reliable than any conventional absolute encoder of comparable resolution and accuracy. The **Vx35H** is available in three accuracy grades. All **Vx35Hs** share these features:

- LED illumination for long life 100,000 hours
- Differential photodetectors for stable signals
- Small number of wires from the encoder
- Availability of non-binary resolutions
- Differential output for noise immunity

ISO
9001
CERTIFIED

Gurley Precision Instruments
514 Fulton Street
Troy, NY 12180 U.S.A.
(800) 759-1844, (518) 272-6300, fax (518) 274-0336,
Online at www.gurley.com, e-mail: info@gurley.com



ingenuity@work

SPECIFICATIONS

	See Note	Model V135H	Model V235H	Model V435H
Line count on disc	1	4096 (2 ¹²)		
Initialization angle		1.05°		
Accuracy, ± arcsec (at 20°C)	2	60	30	15
Maximum output frequency	3	50 kHz = 732 RPM (Max. speed may be limited by subsequent electronics; see data sheet for Model VB or VF interpolating decoder.)		
Maximum weight, oz (g)		25 (715)		
Starting torque, in-oz (N-m) @20°C		2.0 (0.014)		
Running torque, in-oz (N-m) @20°C		1.0 (0.007)		
Moment of inertia, in-oz-s ² (g-cm ²)		0.022 (1600)		
Maximum acceleration, rad/s ²		7.4 x 10 ⁴		
Operating temperature, °F (°C)		41 to 158 (5 to 70)		
Storage temperature, °F (°C)		0 to 160 (-18 to 71)		
Humidity, % rh, non-condensing		98		
Shock		50 g, 11 ms		
Vibration		15 g, 0-2000 Hz		
Bearings		See BEARING LUBRICANTS table		

NOTES:

1. The system can provide non-binary resolutions such as 0.005° or 0.1 mrad. Consult factory for details.
2. This is the total encoder error from all sources. Error is defined at the signal transitions and therefore does not include quantization error, which is ±1/2 quantum. ("Quantum" is the final resolution of the encoder; e.g., for a 17-bit encoder, 1 quantum = 10 s.) Accuracy is guaranteed at 20°C.
3. Higher shaft speeds available; contact factory.

As part of our continuing product improvement program, all specifications are subject to change without notice.



SPECIFICATIONS

INPUT POWER

+5VDC $\pm 0.25V$ @ 75 mA max, available from VB or VF interpolating decoder. Separate power supply is not required. See **VB** or **VF** data sheet.

OUTPUT SIGNALS

Complemented buffered sinusoids.

Sin and Cos: 1 Vpp typical. Pseudorandom index track: 0.25Vpp typical.

THEORY OF OPERATION SHORT VERSION

Virtual Absolute (VA) discs and scales are similar to incremental discs and scales in that they contain a cyclic track and an index track. In an incremental encoder, the index occurs at one place in the full travel, but in a VA encoder, the index track is a continuous serial code (similar in appearance to a bar code). You don't know position immediately upon start-up, as you do in a conventional absolute, but after a very short travel, *in either direction and starting from anywhere*, you know exactly where you are. In the **Vx35H**, this initialization angle is 1.05°. From then on, the encoder is truly absolute. (There are ways to build a pseudorandom encoder so that absolute information is available on power-up without initializing, but these techniques require far more complex sensing hardware; they often impose slower operation as well. And none of them offers the sophisticated built-in testing of GPI's *Virtual Absolute* technology.)

To complete the system, the **Vx35H** is used with one of Gurley's **Interpolating Decoders**. The size of a credit card, it contains patented high-speed circuitry to decode the special serial index track and interpolation to increase the final resolution. In addition to the natural binary position output, a *Status* bit is provided to tell you when the encoder is initialized. This bit is at a logic high whenever the initializing motion is not yet complete, or when some other problem such as supply voltage interruption, electrical noise, damage, or fouling of the disc interferes with the proper code sequence from the index track. When these self-tests are all satisfied, the status bit is low, indicating the position data output is valid.

Final resolution depends on which version of interpolating decoder is used. With the Model **VB**, final resolution is 17 bits (131,072 measuring steps/rev). With the Model **VF**, final resolution is 20 bits (1,048,576 measuring steps/rev), but the max speed is lower.

For a more thorough discussion, refer to the Model **VB** or **VF** data sheet.

ELECTRICAL CONNECTIONS

Output Functions	Wire Colors Conn. Code P	Pin #, DA-15P Conn. Code Q	Pin #, DE-15P Conn. Code R	Pin #, AMP 102387-1 Conn. Code V
SIN	Yellow	8	8	4
/ SIN	Brown	7	7	3
COS	Green	5	5	2
/ COS	Orange	4	4	1
IND	Blue	2	2	5
/ IND	White	1	1	6
+V	Red	10	10	7
COMMON	Black	13	13	8
CASE	Bare (shield) *	9	9	10

* The bare wire (shield) is connected to the encoder case.

Use connector code **V** if the encoder will be connected to a **VB** or **VF** interpolating decoder.

Use connector code **R** if there will be a **CAX###** extension cable between the encoder and the **VB** or **VF** interpolating decoder.

Use connector code **Q** if the encoder will be connected to a Model **DVR** display unit. (The **VB** or **VF** interpolating decoder is inside the DVR.)

SPECIFICATIONS

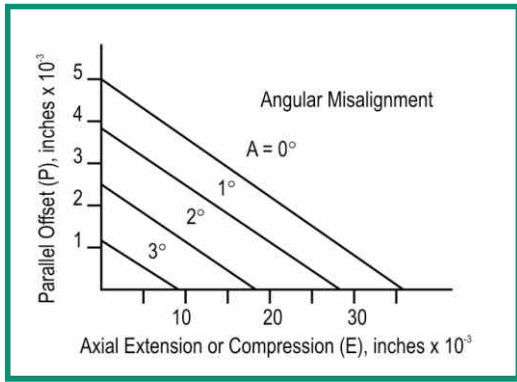

INTERFACE CONSTRAINT
FOR LARGE SHAFTS

Shaft dia, inches	Max angular misalignment, degrees
1.250	0.25
1.125	1.6
1.000	3.2

INTERNAL SHAFT COUPLING

A flexible metal bellows and clamping ring form an accurate coupling that absorbs normal installation misalignments and prevents damage to the encoder bearings. Keeping the misalignments within the following constraints will assure infinite life of the coupling, but may introduce some error. To preserve the encoder's accuracy, misalignments should be kept as low as possible.

$$100P + 14E + 0.125A = 0.5$$

P = parallel offset, inches (0.005 max)

E = axial extension or compression, inches (0.035 max)

A = angular misalignment, degrees (4 max)

Parallel offset, **P**, is equal to the total offset between the centerline of the encoder and the centerline of the user's shaft, plus half the radial run-out of the user's shaft (TIR/2).

SEALS

When ordered with optional shaft seals, the encoder has a magnetic-liquid seal at the base end and a V-ring seal at the clamp end. The magnetic-liquid seal consists of an oil film with suspended magnetic particles. The medium, which is held in place magnetically, forms an effective seal against airborne particulates. The nitrile rubber V-ring seal comprises a flexible lip attached to the seal body with an integral resilient "hinge." It rotates with the shaft and seals axially against a stationary surface. The flexible lip and hinge provide effective sealing even with end play or shaft misalignment. With the seal option, the maximum recommended shaft speed is 4400 rpm.

BEARING LUBRICANTS

The standard lubricant, *Andok® C*, is specifically formulated for severe service, high speed, long life, low torque and low temperature rise; it is suitable for most applications. *Braycote® 601EF* is a low-vapor-pressure lubricant for use in vacuum and clean-room applications at the expense of slightly higher torque.*

Base code	Mounting	Lubricant	Shaft seals	Max slew speed, rpm
A	Synchro/face	Andok C	No	12,000
B	Synchro/face	Andok C	Yes	4,400
C	Square-flange	Andok C	No	12,000
D	Square-flange	Andok C	Yes	4,400
E	Synchro/face	Braycote 601EF	No	8,000
F	Square-flange	Braycote 601EF	No	8,000

Bearings that are subject to oscillatory motion, i.e., partial revolutions and frequent reversals, or very low speed operation (< 100 rpm) may exhibit reduced service life, rotational torque variations and other undesirable behavior. Consult factory if your application requires either oscillatory or very low speed operation.

*Andok and Braycote are brand names of Exxon Corp and Castrol Industrial North America, respectively. GPI reserves the right to change to equivalent lubricants without notice.



OUTLINE DIMENSIONS

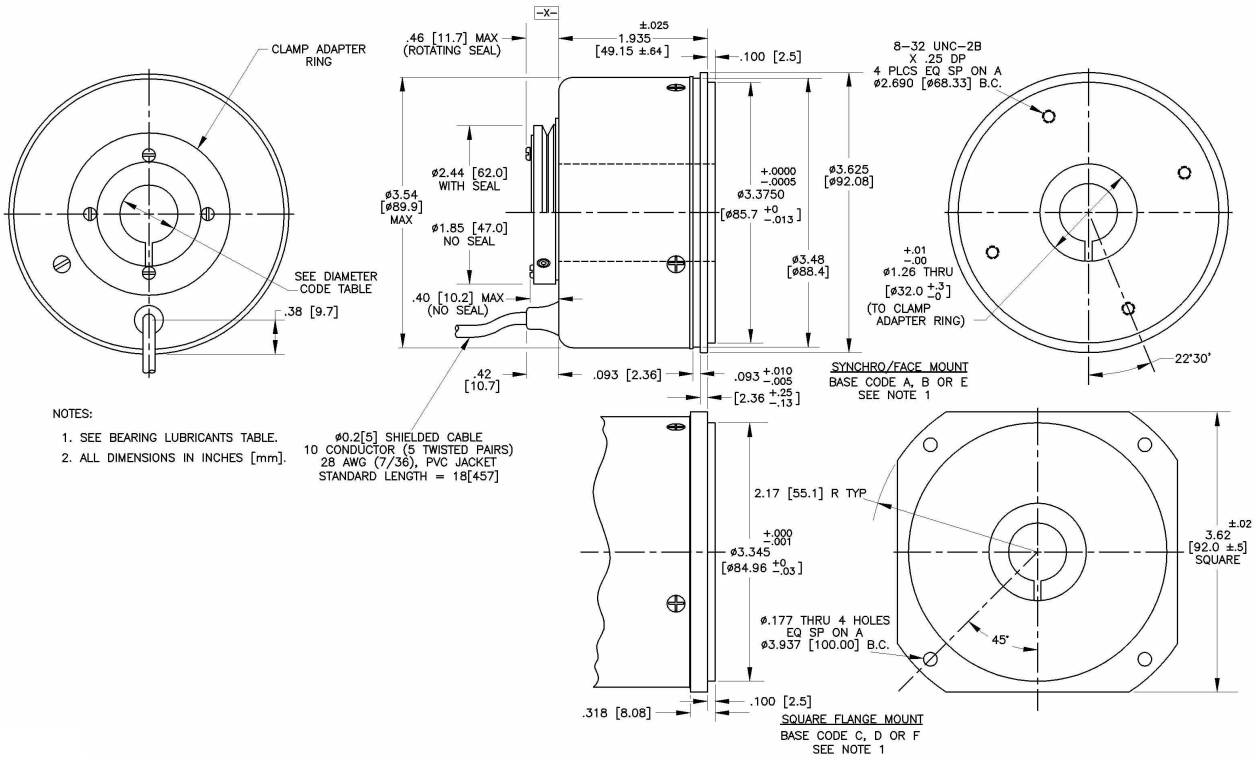

User's Shaft Outside Dia (1)		DIAMETER CODE	Clamp Ring Inside Dia
+0.000/-0.001 in	1.250 in	20E	1.250 in
	1.125 in	18E	1.125 in
	1.000 in	16E	1.000 in
	0.875 in	14E	0.875 in
	0.750 in	12E	0.750 in
	0.625 in	10E	0.625 in
	0.500 in	08E	0.500 in
	0.375 in	06E	0.375 in
	.03125 in	05E	.03125 in
+0.000/-0.028 mm	0.250 in	04E	0.250 in
	30.00 mm	30M	30.00 mm
	25.00 mm	25M	25.00 mm
	20.00 mm	20M	20.00 mm
	10.00 mm	10M	10.00 mm



ORDERING INFORMATION

MODEL	SHAFT	RES	OUTPUT	INTERP	BASE	CAB	EXIT	CONN	DIA	TEMP	SF
	H		M	00			T			C	

MODEL

V135 ±60 s accuracy
V235 ±30 s accuracy
V435 ±15 s accuracy

SHAFT

H Hollow shaft

RES

04096 Disc Resolution, lines. (For non-binary resolution, consult factory)

OUTPUT

M Differential buffered sinusoids

INTERP

00 0 bits of internal interpolation

BASE

A Synchro/face mount, no shaft
B Synchro/face mount, with shaft seals, Andok
C Square flange mount, no shaft seals, Andok
D Square flange mount, with shaft seals, Andok
E Synchro/face mount, no shaft seals, Baycote
F Square flange mount, no shaft seals, Baycote

CAB

Cable length, inches (04-99)
18 Standard

EXIT

T Top cable exit

CONN

P Pigtails (no connector)
V Amp 102837-1; use to connect encoder cable to **VB** Interpolating Decoder
R DE-15P; use if there will be a **CAX###** extension cable between the **Vx35H** and **VB**
Q DA-15P; use with Model **DVR** Display Unit

DIA

See DIAMETER CODE table
E ## = sixteenths of an inch
M ## = millimeters

TEMP

C 0°C to 70°C operating temperature range

SF

Issued at time of order to cover special customer requirements
N No special features

ACCESSORIES (order separately)

VB Interpolating decoder; see separate data sheet
VF Interpolating decoder; see separate data sheet
AX06399 Synchro cleats to mount **Vx35H**
CAX### Extension cable assembly, ### inches long. (enc. cable + ext. cable = 600 max)

SPECIAL CAPABILITIES

For special situations, we can optimize catalog encoders to provide higher frequency response, greater accuracy, wider temperature range, reduced torque, non-standard line counts, or other modified parameters. In addition, we regularly design and manufacture custom encoders for user-specific requirements. These range from high-volume, low-cost, limited-performance commercial applications to encoders for military, aerospace and similar high-performance, high-reliability conditions. We would welcome the opportunity to help you with your encoder needs.

WARRANTY

Gurley Precision Instruments offers a limited warranty against defects in material and workmanship for a period of one year from the date of shipment.



Gurley Precision Instruments
 514 Fulton Street
 Troy, NY 12180 U.S.A.
 (800) 759-1844, (518) 272-6300, fax (518) 274-0336,
 Online at www.gurley.com, e-mail: info@gurley.com

